

### Features

- Ultra low capacitance: 10pF typical
- Ultra low leakage: nA level
- Operating voltage: 48V
- Complies with following standards:
  - IEC 61000-4-2 (ESD) immunity test
    - Air discharge:  $\pm 25\text{kV}$
    - Contact discharge:  $\pm 25\text{kV}$
  - IEC61000-4-5 (Lightning) 4A (8/20  $\mu\text{s}$ )
- RoHS Compliant

### Dimensions SOD-323



### Applications

- Cell Phone Handsets and Accessories
- Microprocessor based equipment
- Personal Digital Assistants (PDA's)
- Notebooks, Desktops, and Servers
- Portable Instrumentation
- Networking and Telecom
- Serial and Parallel Ports
- Peripherals

### Pin Configuration

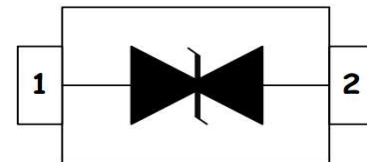

### Mechanical Characteristics

- Package: SOD-323
- Lead Finish: Matte Tin
- Quantity Per Reel: 3,000 pcs
- Reel Size: 7 inch
- Device Marking: 2P

### Absolute Maximum Ratings (Tamb=25°C unless otherwise specified)

Symbol	Parameter	Value	Unit
PPK	Peak Pulse Power	350	W
IPP	Peak Pulse Current	4	A
VESD (Contact)	Contact ESD Voltage per IEC61000-4-2	25	kV
VESD (Air)	Air ESD Voltage per IEC61000-4-2	25	kV
TJ	Junction Temperature	-55 to +150	°C
TSTG	Storage Temperature	-55 to +150	°C

**Electrical Characteristics**(TA=25°C unless otherwise specified)

Symbol	Parameter	Conditions	Min	Typ	Max	Unit
VRWM	Reverse Working Peak Voltage				48	V
VBR	Reverse Breakdown Voltage	IT = 1mA	50	56	60	V
IR	Reverse Leakage Current	VRWM =48V			0.2	μA
VC	Clamping Voltage	IPP = 1A (8/20μs)		70	85	V
VC	Clamping Voltage	IPP = 4A (8/20 μs)		85	100	V
CJ	Capacitance	VR = 0V, f = 1MHz		10	20	pF

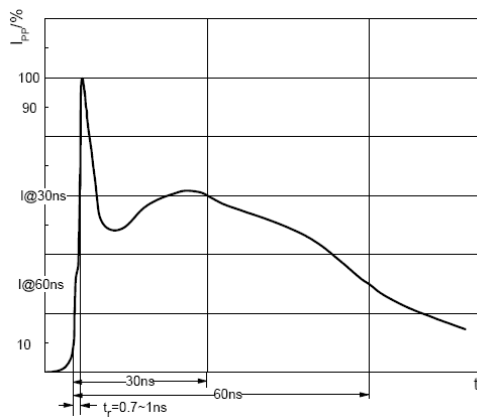
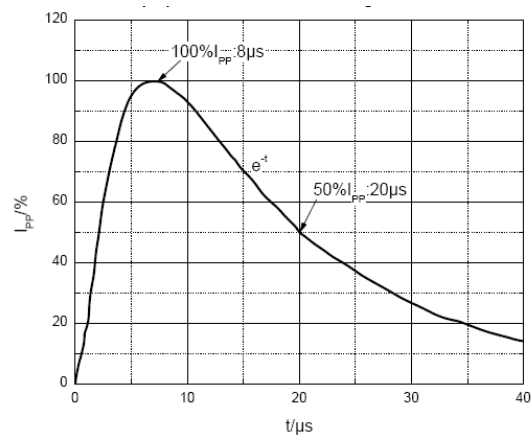
**Typical Performance Characteristics (TA=25°C unless otherwise Specified)**

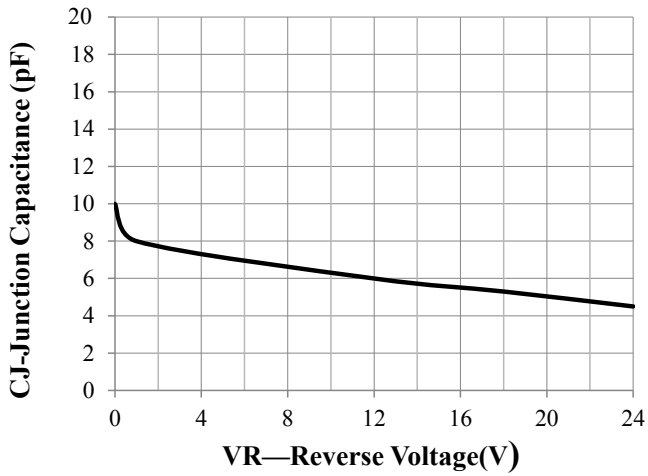
**ESD pulse waveform according to IEC61000-4-2**

**8/20μs pulse waveform according to IEC 61000-4-5**

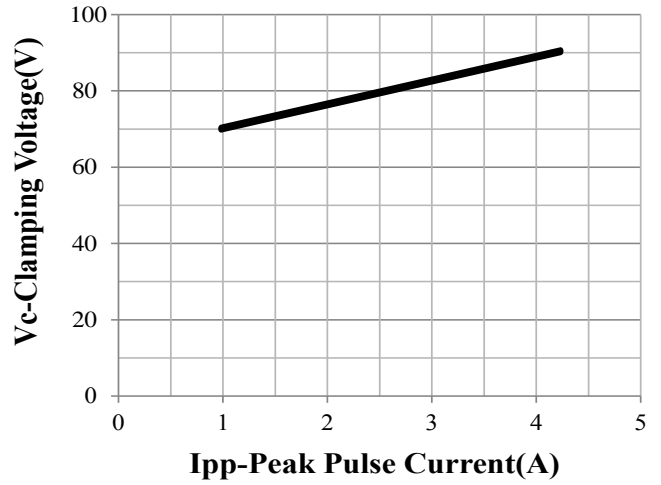

Junction Capacitance vs. Reverse Voltage

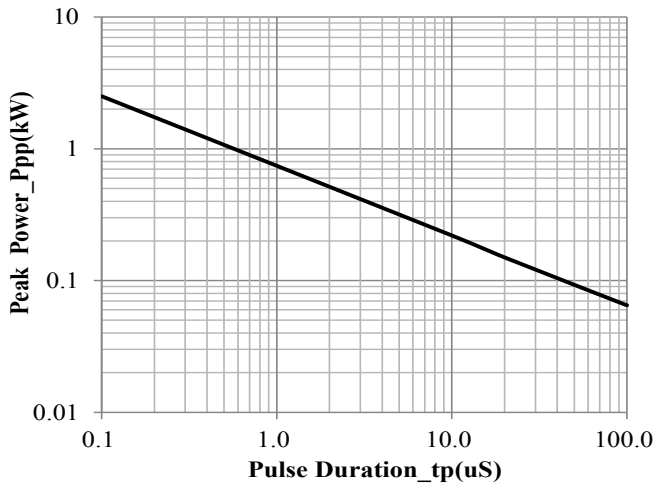

Clamping Voltage vs. Peak Pulse Current



Peak Pulse Power vs. Pulse Time

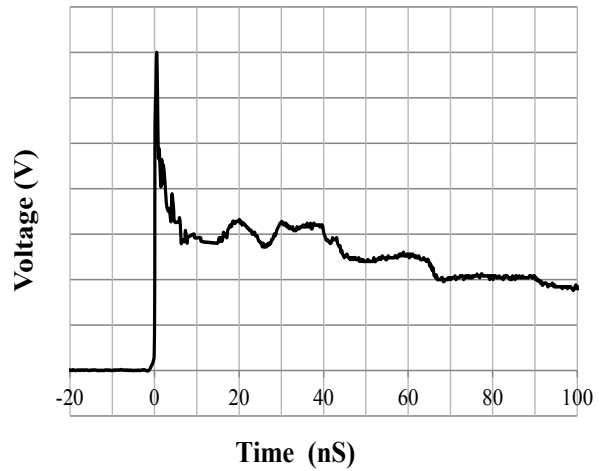

IEC61000-4-2 Pulse Waveform

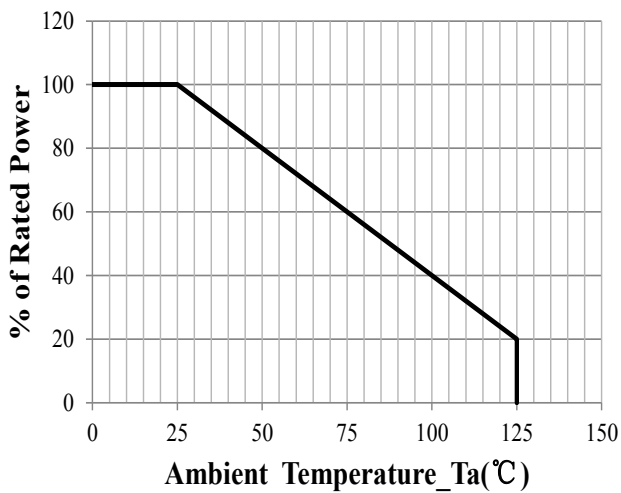

Power Derating Curve

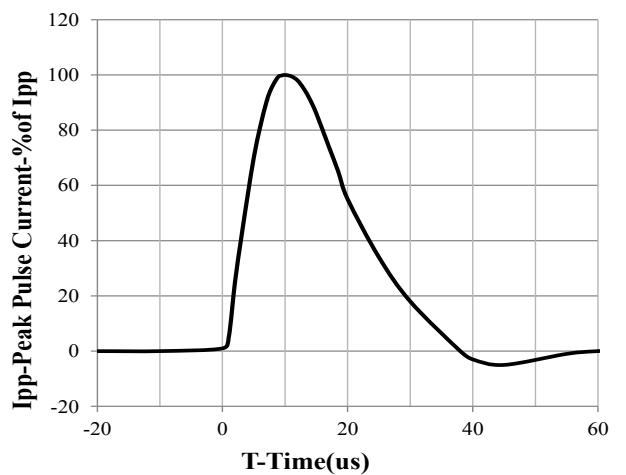

8 X 20us Pulse Waveform

## SOD-323 Package Outline & Dimensions

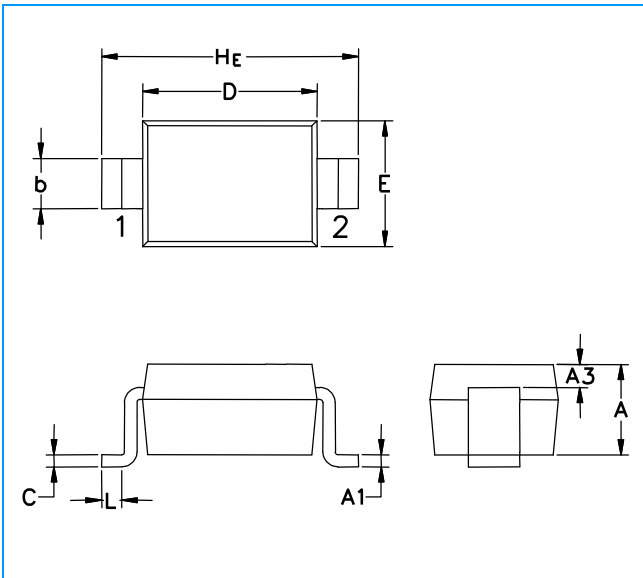

Symbol	Millimeters			Inches		
	Min.	Nom.	Max.	Min.	Nom.	Max.
<b>A</b>	0.80	0.90	1.00	0.031	0.035	0.040
<b>A1</b>	0.00	0.05	0.10	0.000	0.002	0.004
<b>A3</b>	0.15 REF			0.006 REF		
<b>b</b>	0.25	0.32	0.40	0.010	0.012	0.016
<b>C</b>	0.089	0.12	0.177	0.003	0.005	0.007
<b>D</b>	1.60	1.70	1.80	0.062	0.066	0.070
<b>E</b>	1.15	1.25	1.35	0.045	0.049	0.053
<b>L</b>	0.08			0.003		
<b>HE</b>	2.30	2.50	2.70	0.090	0.098	0.105

### Soldering Footprint

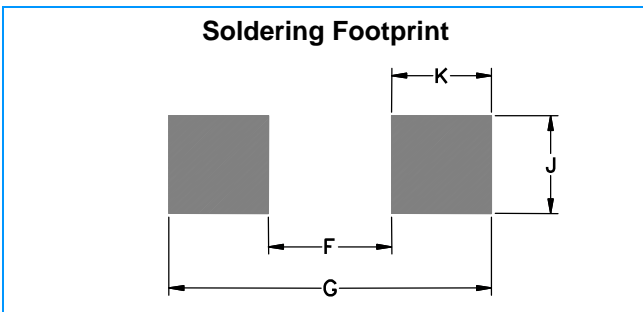

Symbol	Millimeters	Inches
<b>F</b>	1.60	0.063
<b>G</b>	2.85	0.112
<b>J</b>	0.83	0.033
<b>K</b>	0.63	0.025