

Features

- Low profile package
- Ideal for automated placement
- Low power losses, high efficiency
- Low forward voltage drop
- High surge capability
- High temperature soldering:
260°C/10 seconds at terminals
- Component in accordance to
RoHS 2002/95/1 and WEEE 2002/96/EC



SMB (DO – 214AA)

Mechanical Data

- **Case:** JEDEC DO-214AA molded plastic
- **Terminals:** Solder plated, solderable per
JESD22-B102D
- **Polarity:** Laser band denotes cathode end

Major Ratings and Characteristics

$I_{F(AV)}$	2.0A
V_{RRM}	20 V to 100 V
I_{FSM}	50A
V_F	0.50V, 0.55V, 0.70V, 0.85V
$T_j \text{ max.}$	125 °C

Maximum Ratings & Thermal Characteristics

($T_A = 25\text{ °C}$ unless otherwise noted)

Items	Symbol	SS22B	SS23B	SS24B	SS25B	SS26B	SS28B	SS210B	UNIT
Maximum repetitive peak reverse voltage	V_{RRM}	20	30	40	50	60	80	100	V
Maximum RMS voltage	V_{RMS}	14	21	28	35	42	56	70	V
Maximum DC blocking voltage	V_{DC}	20	30	40	50	60	80	100	V
Maximum average forward rectified current	$I_{F(AV)}$	2.0							A
Peak forward surge current 8.3 ms single half sine-wave superimposed on rated load	I_{FSM}	50							A
Voltage rate of change (rated V_R)	dv/dt	10000							V/ μ s
Thermal resistance from junction to lead ⁽¹⁾	$R_{\theta JL}$	25							°C/W
Operating junction and storage temperature range	T_J, T_{STG}	-65 to +125							°C

Note 1: Mounted on P.C.B. with 0.28 x 0.28" (7.0 x 7.0mm) copper pad areas.

Electrical Characteristics ($T_A = 25\text{ °C}$ unless otherwise noted)

Items	Test conditions	Symbol	SS22B	SS23~24B	SS25~26B	SS28~210B	UNIT	
Instantaneous forward voltage	$I_F=2.0A^{(2)}$	V_F	0.50	0.55	0.70	0.85	V	
Reverse current	$V_R=V_{DC}$	I_R	$T_J=25\text{ °C}$				0.5	mA
			$T_J=100\text{ °C}$					

Note 2: Pulse test:300 μ s pulse width,1% duty cycle.

Characteristic Curves ($T_A=25^\circ\text{C}$ unless otherwise noted)

Fig.1 Forward Current Derating Curve

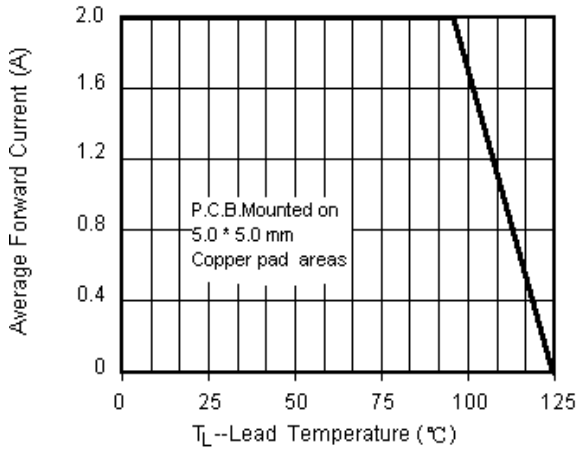

Fig.2 Maximum Non-Repetitive Peak Forward Surge Current

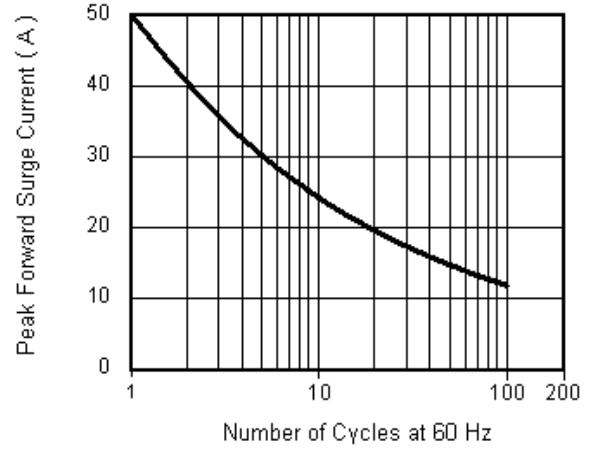

Fig.3 Typical Instantaneous Forward Characteristics

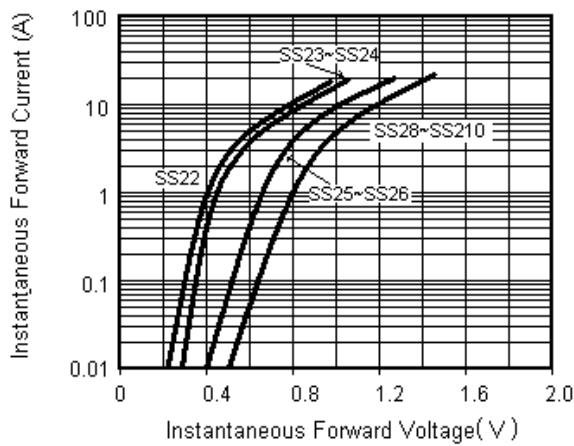
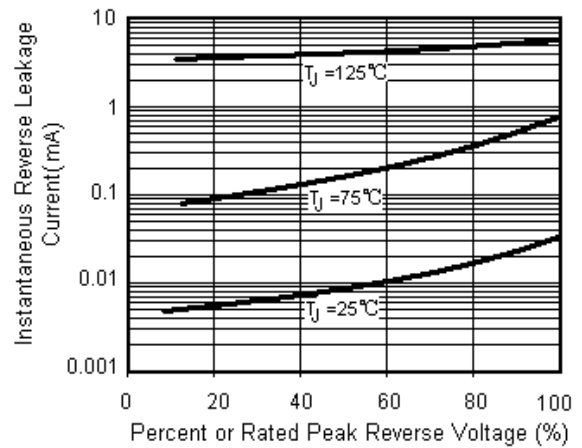
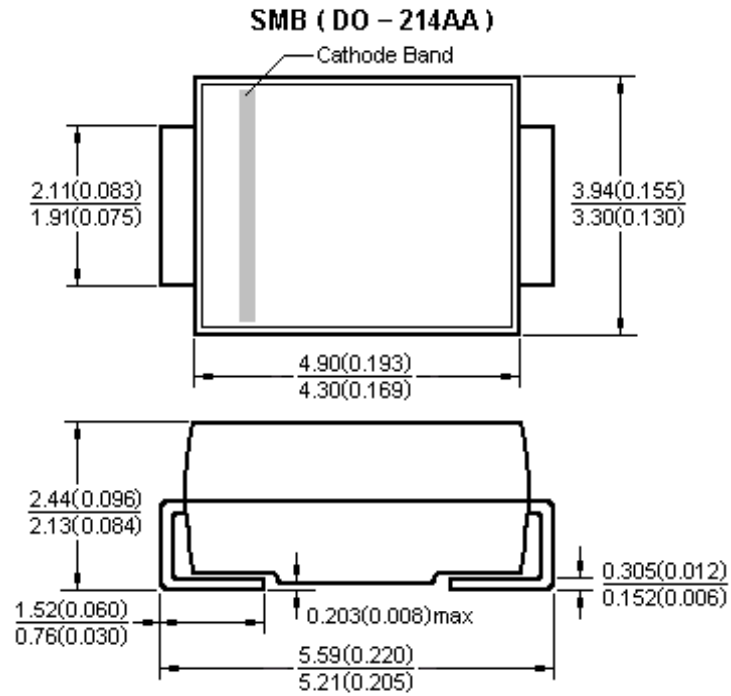

Fig.4 Typical Reverse Leakage Characteristics



Package Outline



Dimensions in millimeters and (inches)