

Features

- Low profile space
- Ideal for automated placement
- Glass passivated chip junctions
- Low forward voltage drop
- Low leakage current
- High forward surge capability
- High temperature soldering:
260°C/10 seconds at terminals
- Component in accordance to
RoHS 2002/95/1 and WEEE 2002/96/EC



SMB (DO – 214AA)

Mechanical Date

- **Case:** JEDEC DO-214AA molded plastic body over glass passivated chip
- **Terminals:** Solder plated, solderable per J-STD-002B and JESD22-B102D
- **Polarity:** Laser band denotes cathode end

Major Ratings and Characteristics

$I_{F(AV)}$	3.0 A
V_{RRM}	50 V to 1000 V
I_{FSM}	100 A
I_R	5 μ A
V_F	1.1 V
$T_j \text{ max.}$	150 °C

Maximum Ratings & Thermal Characteristics

($T_A = 25^\circ\text{C}$ unless otherwise noted)

Items	Symbol	S3A	S3B	S3D	S3G	S3J	S3K	S3M	UNIT
Maximum repetitive peak reverse voltage	V_{RRM}	50	100	200	400	600	800	1000	V
Maximum RMS voltage	V_{RMS}	35	70	140	280	420	560	700	V
Maximum DC blocking voltage	V_{DC}	50	100	200	400	600	800	1000	V
Maximum average forward rectified current	$I_{F(AV)}$	3							A
Peak forward surge current 8.3 ms single half sine-wave superimposed on rated load	I_{FSM}	100							A
Thermal resistance from junction to lead ⁽¹⁾	$R_{\theta JL}$	25							°C/W
Operating junction and storage temperature range	T_J, T_{STG}	-55 to +150							°C

Note 1: Mounted on P.C.B. with 0.28 x 0.28" (7.0 x 7.0mm) copper pad areas.

Electrical Characteristics ($T_A = 25^\circ\text{C}$ unless otherwise noted)

Items	Test conditions	Symbol	Min	Type	Max	UNIT
Instantaneous forward voltage	$I_F=3 \text{ A}^{(2)}$	V_F	-	0.98	1.10	V
Reverse current	$V_R=V_{DC}$ $T_j=25^\circ\text{C}$ $T_j=125^\circ\text{C}$	I_R	-	-	5 50	μ A
Typical junction capacitance	4.0 V, 1MHz	C_J	-	60.0	-	pF

Note 2: Pulse test:300 μ s pulse width,1% duty cycle.

Characteristic Curves ($T_A=25\text{ }^\circ\text{C}$ unless otherwise noted)

Fig.1 Forward Current Derating Curve

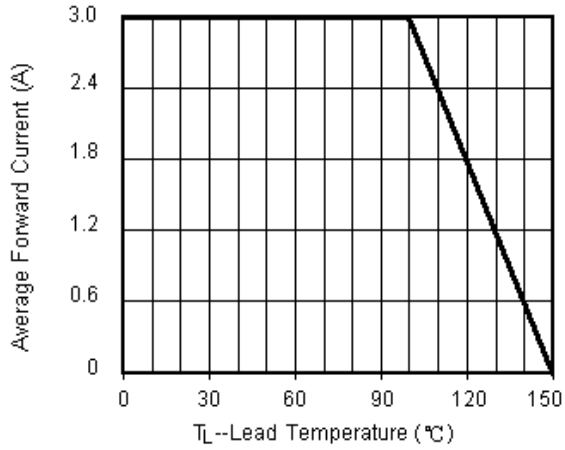

Fig.2 Maximum Non-Repetitive Peak Forward Surge Current

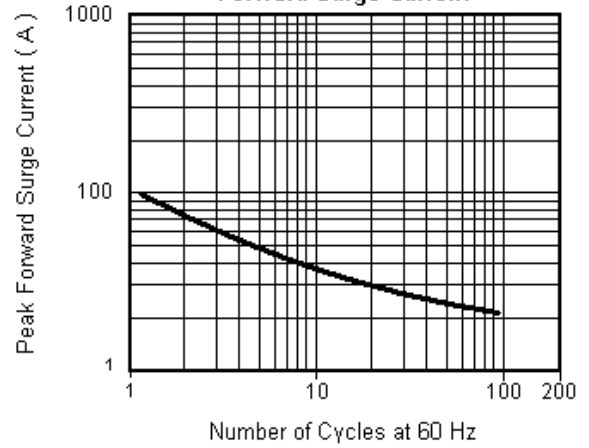

Fig.3 Typical Instantaneous Forward Characteristics

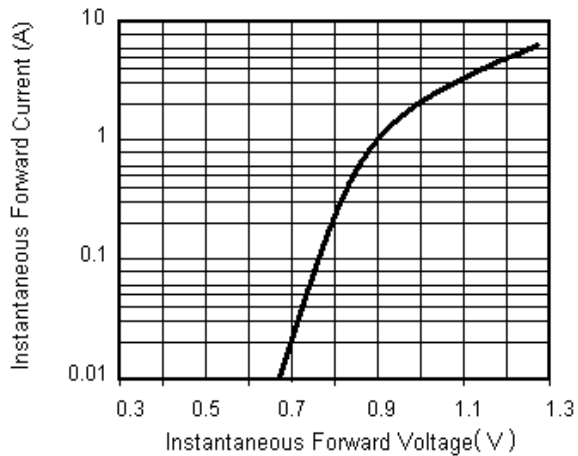
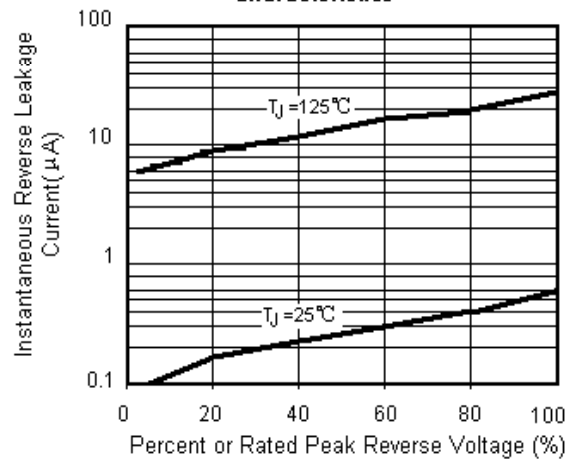
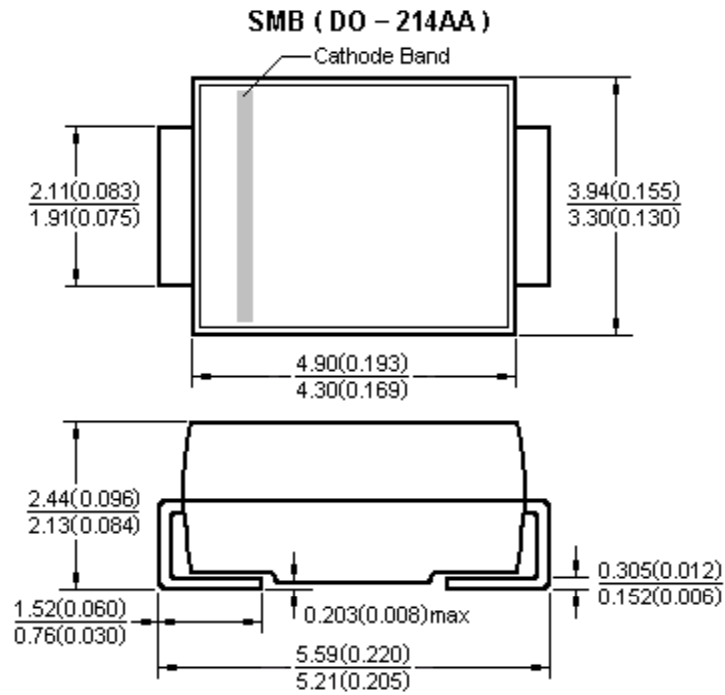

Fig.4 Typical Reverse Leakage Characteristics



Package Outline



Dimensions in millimeters and (inches)