

Description

The LM3L5P04 uses advanced trench technology to provide excellent $R_{DS(ON)}$, low gate charge and operation with gate voltages as low as 4.5V. This device is suitable for use as a Battery protection or in other Switching application.

General Features

$V_{DS} = -40V$ $I_D = -5.0A$

$R_{DS(ON)} < 70m\Omega$ @ $V_{GS} = -10V$

Application

- Battery protection
- Load switch
- Uninterruptible power supply

Dimensions SOT-23-3



Pin Configuration

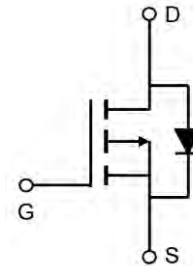

Package Marking and Ordering Information

Device	Device Marking	Device Package	Reel Size	Tape width	Quantity
LM3L5P04	5P40	SOT-23-3	Ø180mm	8mm	3000 units

Absolute Maximum Ratings ($T_c = 25^\circ C$ unless otherwise noted)

Symbol	Parameter	Rating	Units
V_{DS}	Drain-Source Voltage	-40	V
V_{GS}	Gate-Source Voltage	± 20	V
$I_D @ T_A = 25^\circ C$	Continuous Drain Current, $V_{GS} @ -10V^1$	-5	A
$I_D @ T_A = 70^\circ C$	Continuous Drain Current, $V_{GS} @ -10V^1$	-3.8	A
I_{DM}	Pulsed Drain Current ²	-18	A
EAS	Single Pulse Avalanche Energy ³	21	mJ
I_{AS}	Avalanche Current	-20.5	A
$P_D @ T_A = 25^\circ C$	Total Power Dissipation ⁴	1.5	W
T_{STG}	Storage Temperature Range	-55 to 150	$^\circ C$
T_J	Operating Junction Temperature Range	-55 to 150	$^\circ C$
$R_{\theta JA}$	Thermal Resistance Junction-Ambient ¹	85	$^\circ C/W$
$R_{\theta JC}$	Thermal Resistance Junction-Case ¹	50	$^\circ C/W$

Electrical Characteristics (T_J=25°C, unless otherwise noted)

Symbol	Parameter	Conditions	Min.	Typ	Max.	Unit
BVDSS	Drain-Source Breakdown Voltage	V _{GS} =0V , I _D =-250uA	-40	-46	---	V
ΔBVDSS/ΔT _J	BV _{DSS} Temperature Coefficient	Reference to 25°C , I _D =-1mA	---	-0.018	---	V/°C
RDS(ON)	Static Drain-Source On-Resistance ²	V _{GS} =-10V , I _D =-3A	---	65	70	mΩ
		V _{GS} =-4.5V , I _D =-2A	---	85	100	
VGS(th)	Gate Threshold Voltage	V _{GS} =V _{DS} , I _D =-250uA	-1.0	-1.5	-2.5	V
ΔVGS(th)	VGS(th) Temperature Coefficient		---	2.5	---	mV/°C
IDSS	Drain-Source Leakage Current	V _{DS} =-24V , V _{GS} =0V , T _J =25°C	---	---	-1	uA
		V _{DS} =-24V , V _{GS} =0V , T _J =55°C	---	---	-5	
IGSS	Gate-Source Leakage Current	V _{GS} =±20V , V _{DS} =0V	---	---	±100	nA
gfs	Forward Transconductance	V _{DS} =-5V , I _D =-3A	---	5.8	---	S
Q _g	Total Gate Charge (-4.5V)	V _{DS} =-32V , V _{GS} =-4.5V , I _D =-3A	---	6.4	---	nC
Q _{gs}	Gate-Source Charge		---	2.1	---	
Q _{gd}	Gate-Drain Charge		---	2.5	---	
Td(on)	Turn-On Delay Time	V _{DD} =-20V , V _{GS} =-4.5V , R _G =3.3Ω , I _D =-3A	---	4.2	---	ns
T _r	Rise Time		---	23	---	
Td(off)	Turn-Off Delay Time		---	26.8	---	
T _f	Fall Time		---	20.6	---	
Ciss	Input Capacitance	V _{DS} =-15V , V _{GS} =0V , f=1MHz	---	620	---	pF
Coss	Output Capacitance		---	65	---	
Crss	Reverse Transfer Capacitance		---	53	---	
IS	Continuous Source Current ^{1,4}	V _G =V _D =0V , Force Current	---	---	-3.2	A
ISM	Pulsed Source Current ^{2,4}		---	---	-16.1	A
VSD	Diode Forward Voltage ²	V _{GS} =0V , I _S =-1A , T _J =25°C	---	---	-1	V

Note :

- 1、 The data tested by surface mounted on a 1 inch FR-4 board with 2OZ copper.
- 2、 The data tested by pulsed , pulse width ≅ 300us , duty cycle ≅ 2%
- 3、 The power dissipation is limited by 150°C junction temperature
- 4、 The data is theoretically the same as I_D and I_{DM} , in real applications , should be limited by total power dissipation.

Typical Characteristics

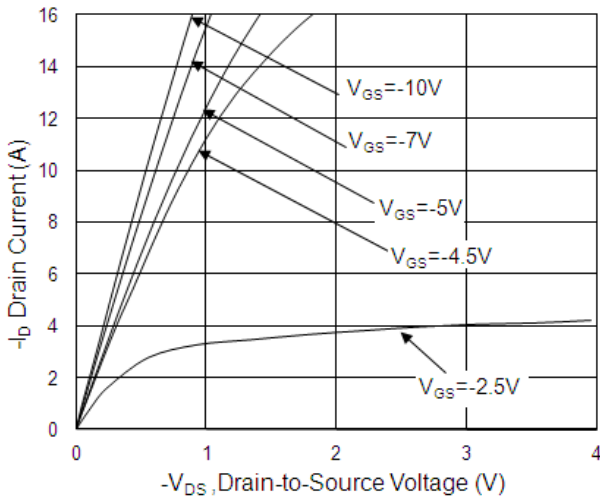

Fig.1 Typical Output Characteristics

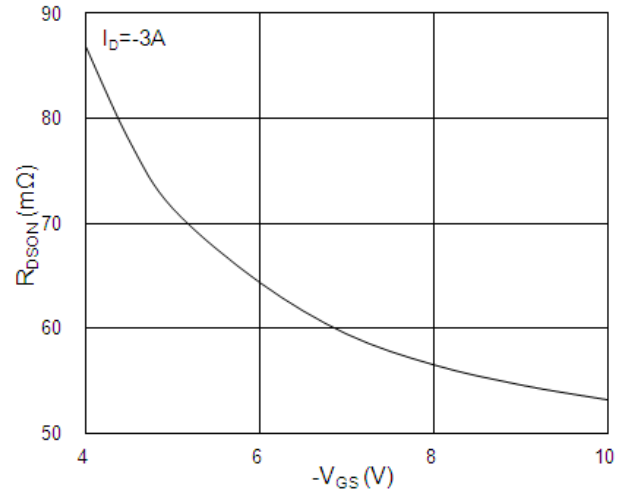

Fig.2 On-Resistance vs. G-S Voltage

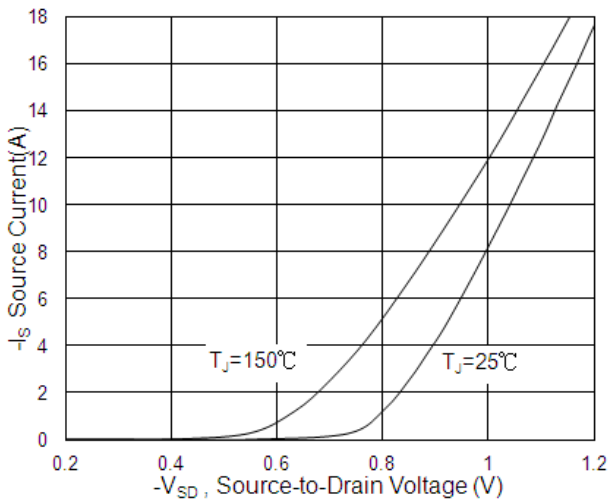

Fig.3 Forward Characteristics Of Reverse

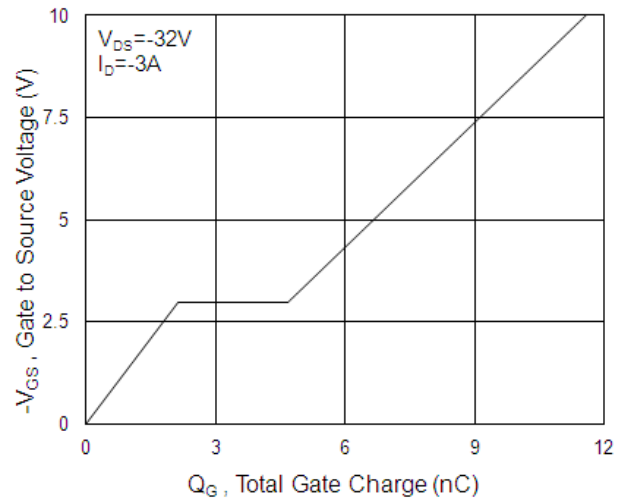

Fig.4 Gate-Charge Characteristics

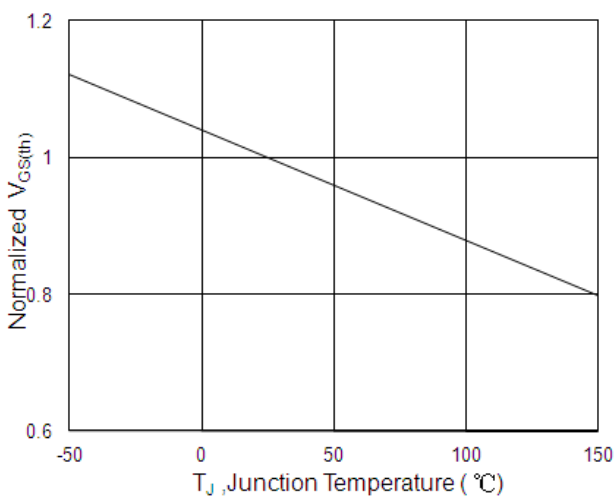

Fig.5 Normalized $V_{GS(th)}$ vs. T_J

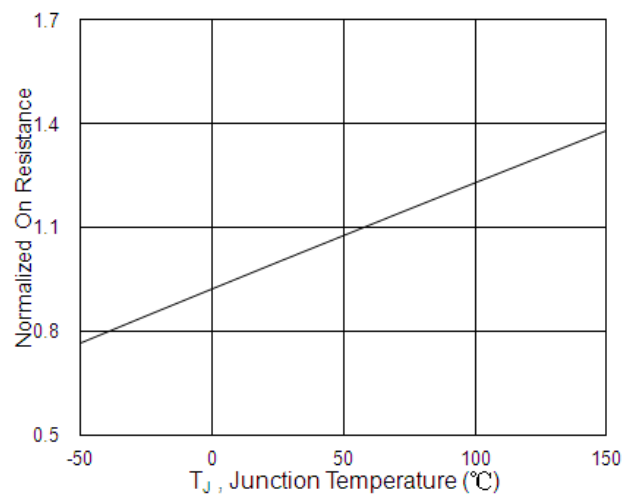

Fig.6 Normalized $R_{DS(on)}$ vs. T_J

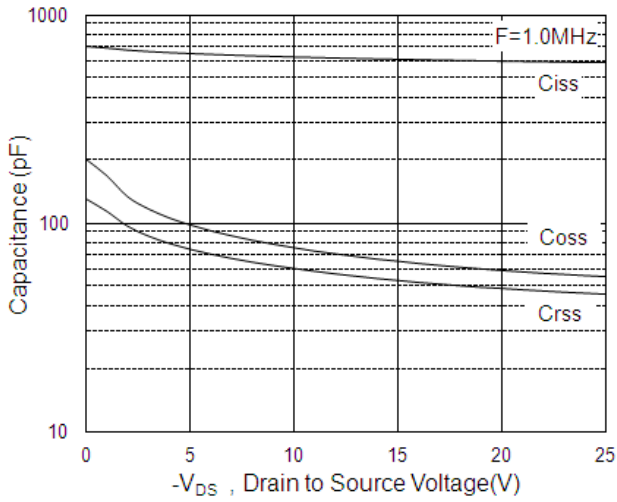

Fig.7 Capacitance

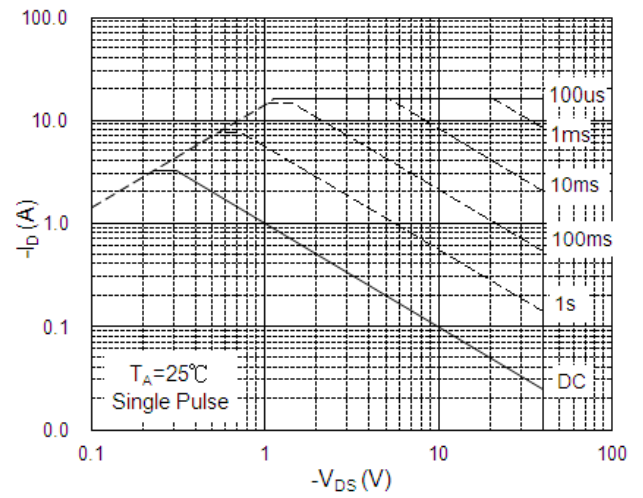

Fig.8 Safe Operating Area

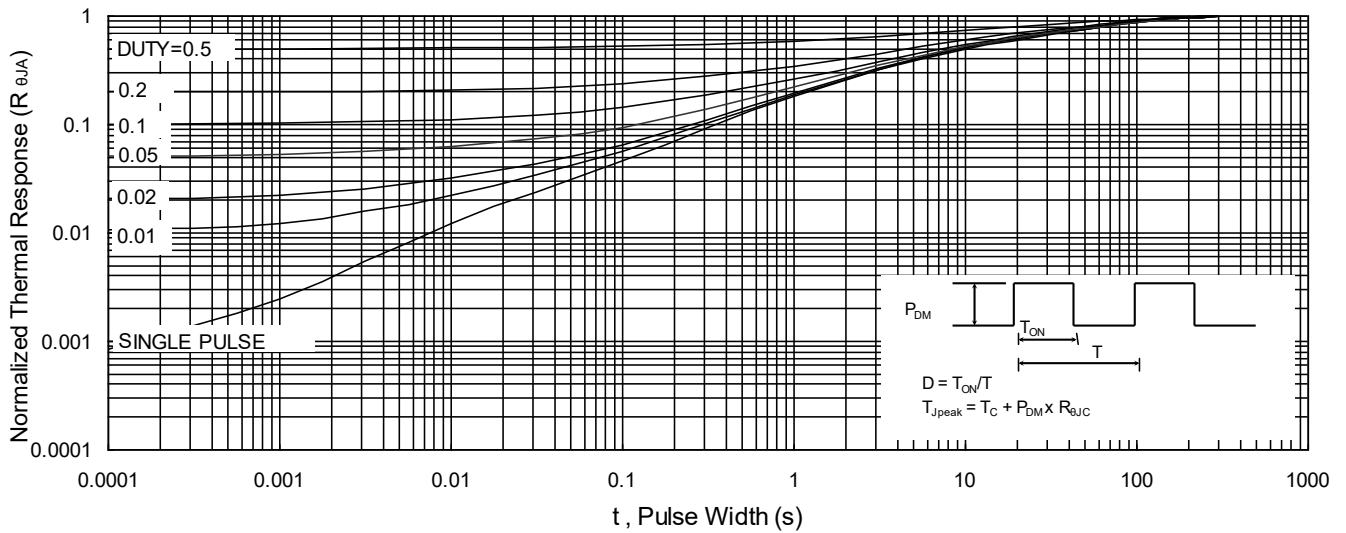

Fig.9 Normalized Maximum Transient Thermal Impedance

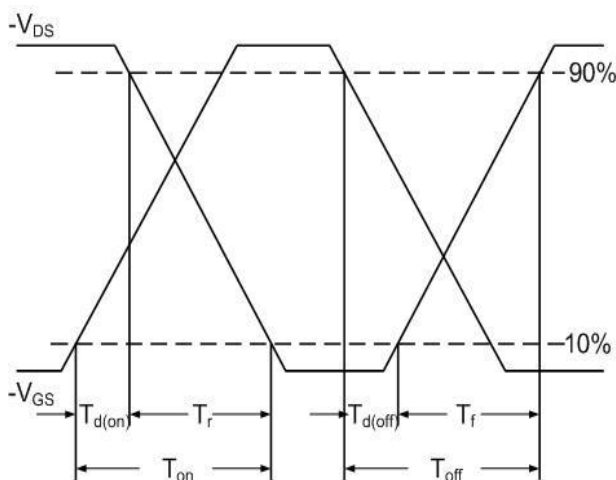

Fig.10 Switching Time Waveform

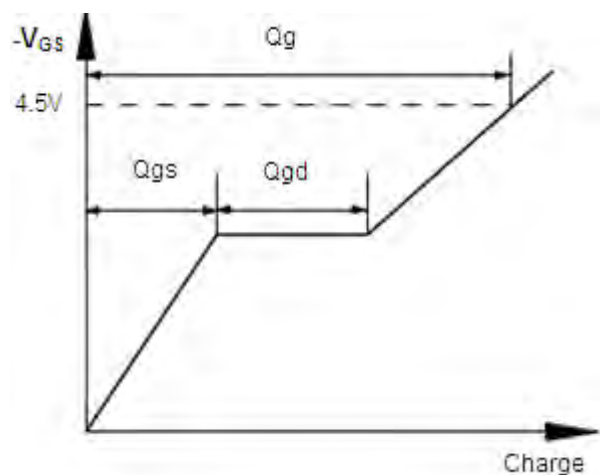
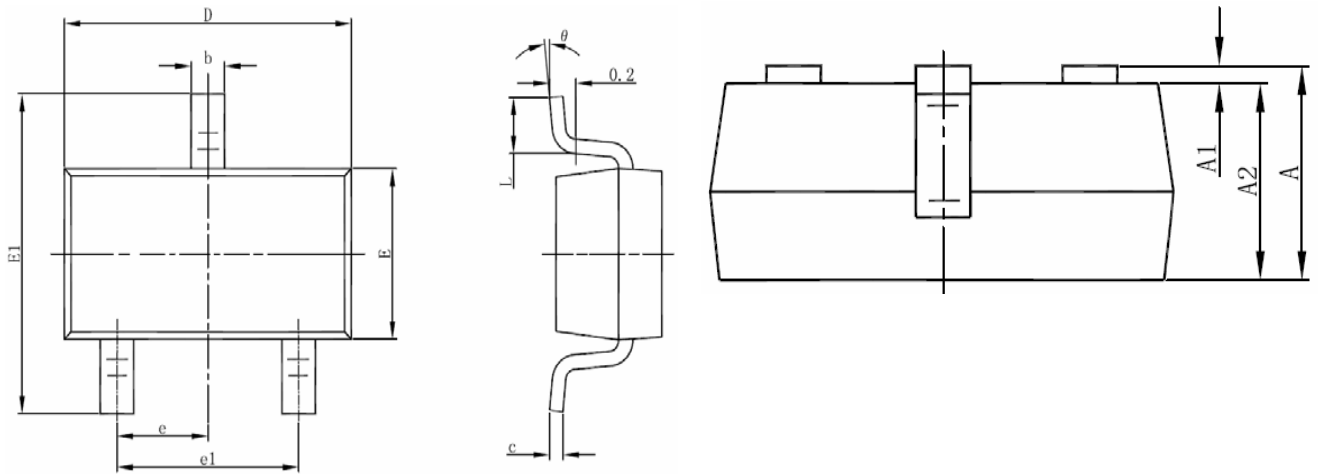

Fig.11 Gate Charge Waveform

SOT-23-3 Package Information



Symbol	Dimensions In Millimeters		Dimensions In Inches	
	Min	Max	Min	Max
A	1.050	1.250	0.041	0.049
A1	0.000	0.100	0.000	0.004
A2	1.050	1.150	0.041	0.045
b	0.300	0.500	0.012	0.020
c	0.100	0.200	0.004	0.008
D	2.820	3.020	0.111	0.119
E	1.500	1.700	0.059	0.067
E1	2.650	2.950	0.104	0.116
e	0.950(BSC)		0.037(BSC)	
e1	1.800	2.000	0.071	0.079
L	0.300	0.600	0.012	0.024
θ	0°	8°	0°	8°

Notes

1. All dimensions are in millimeters.
2. Tolerance $\pm 0.10\text{mm}$ (4 mil) unless otherwise specified
3. Package body sizes exclude mold flash and gate burrs. Mold flash at the non-lead sides should be less than 5 mils.
4. Dimension L is measured in gauge plane.
5. Controlling dimension is millimeter, converted inch dimensions are not necessarily exact.