

FEATURES

- $R_{DS(ON)} \leq 140m\Omega$ (110m Ω Typ.)
@ $V_{GS}=10V$
- $R_{DS(ON)} \leq 300m\Omega$ (160m Ω Typ.)
@ $V_{GS}=4.5V$

APPLICATIONS

- Load Switch
- PWM Application
- Power management

MARKING

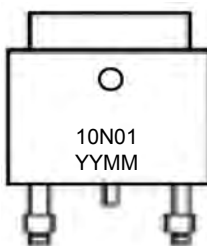

YYMM:Date Code(year&month)

TO-252

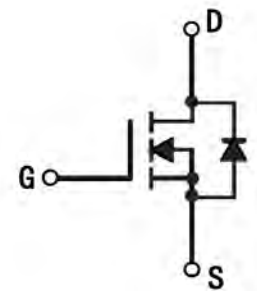
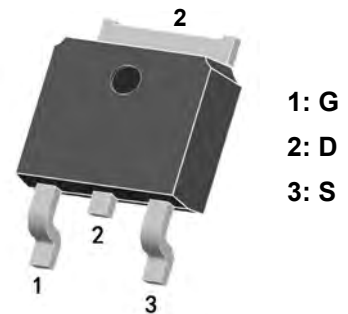

MAXIMUM RATINGS(TC=25°C unless otherwise specified)

Symbol	Parameter	Max.	Units
V_{DSS}	Drain-Source Voltage	100	V
V_{GSS}	Gate-Source Voltage	± 20	V
I_D	Continuous Drain Current	$T_C = 25^\circ C$	10
		$T_C = 100^\circ C$	6.5
I_{DM}	Pulsed Drain Current ^{note1}	40	A
E_{AS}	Single Pulsed Avalanche Energy ^{note2}	2.25	mJ
P_D	Power Dissipation	$T_C = 25^\circ C$	29.4
$R_{\theta JC}$	Thermal Resistance, Junction to Case	4.25	$^\circ C/W$
T_J, T_{STG}	Operating and Storage Temperature Range	-55 to +150	$^\circ C$

ELECTRICAL CHARACTERISTICS TJ=25 °C unless otherwise specified

Symbol	Parameter	Test Condition	Min.	Typ.	Max.	Units
Off Characteristic						
$V_{(BR)DSS}$	Drain-Source Breakdown Voltage	$V_{GS}=0V, I_D=250\mu A$	100	-	-	V
I_{DSS}	Zero Gate Voltage Drain Current	$V_{DS}=100V, V_{GS}=0V,$	-	-	1.0	μA
I_{GSS}	Gate to Body Leakage Current	$V_{DS}=0V, V_{GS}=\pm 20V$	-	-	± 100	nA
On Characteristics						
$V_{GS(th)}$	Gate Threshold Voltage	$V_{DS}=V_{GS}, I_D=250\mu A$	1.5	-	2.5	V
$R_{DS(on)}$	Static Drain-Source on-Resistance <small>note3</small>	$V_{GS}=10V, I_D=5A$	-	110	140	m Ω
		$V_{GS}=4.5V, I_D=3A$	-	160	300	
Dynamic Characteristics						
C_{iss}	Input Capacitance	$V_{DS}=50V, V_{GS}=0V,$ $f=100KHz$	-	206	-	pF
C_{oss}	Output Capacitance		-	29	-	pF
C_{riss}	Reverse Transfer Capacitance		-	1.4	-	pF
Q_g	Total Gate Charge	$V_{DS}=50V, I_D=5A,$ $V_{GS}=10V$	-	4.3	-	nC
Q_{gs}	Gate-Source Charge		-	1.5	-	nC
Q_{gd}	Gate-Drain("Miller") Charge		-	1.1	-	nC
Switching Characteristics						
$t_{d(on)}$	Turn-on Delay Time	$V_{DS}=50V,$ $I_D=5A, R_{GEN}=2\Omega,$ $V_{GS}=10V$	-	14.7	-	ns
t_r	Turn-on Rise Time		-	3.5	-	ns
$t_{d(off)}$	Turn-off Delay Time		-	20.9	-	ns
t_f	Turn-off Fall Time		-	2.7	-	ns
Drain-Source Diode Characteristics and Maximum Ratings						
I_S	Maximum Continuous Drain to Source Diode Forward Current		-	-	10	A
I_{SM}	Maximum Pulsed Drain to Source Diode Forward Current		-	-	40	A
V_{SD}	Drain to Source Diode Forward Voltage	$V_{GS}=0V, I_S=10A$	-	-	1.2	V
t_{rr}	Body Diode Reverse Recovery Time	$I_F=5A, di/dt=100A/\mu s$	-	32	-	ns
Q_{rr}	Body Diode Reverse Recovery Charge		-	39	-	nC

- Notes: 1. Repetitive Rating: Pulse Width Limited by Maximum Junction Temperature
 2. EAS condition: $T_J=25^\circ C, V_{DD}=50V, V_G=10V, R_G=50\Omega, L=0.5mH, I_{AS}=3A$
 3. Pulse Test: Pulse Width $\leq 300\mu s$, Duty Cycle $\leq 0.5\%$

TYPICAL PERFORMANCE CHARACTERISTICS

Figure 1: Output Characteristics

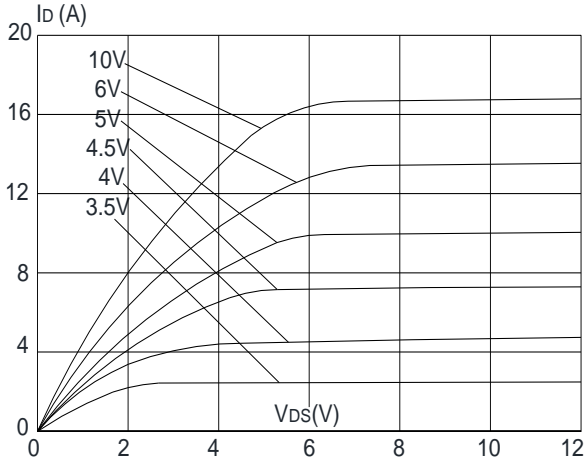

Figure 2: Typical Transfer Characteristics

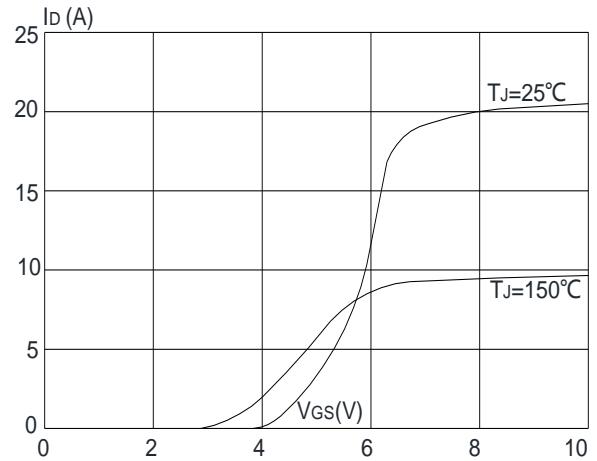

Figure 3: On-resistance vs. Drain Current

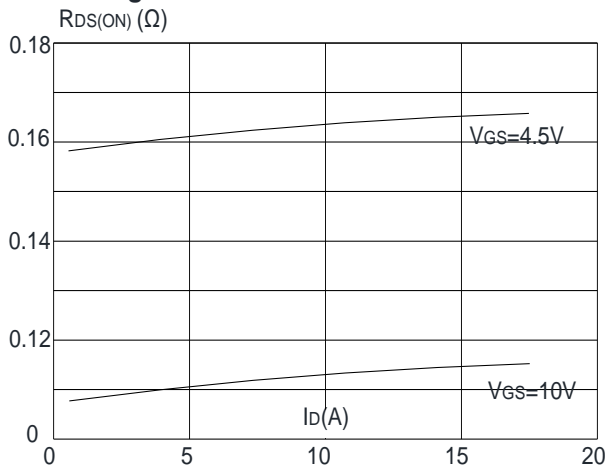

Figure 4: Body Diode Characteristics

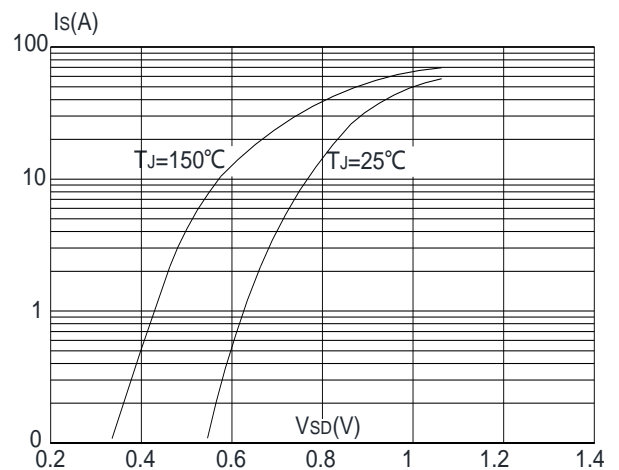

Figure 5: Gate Charge Characteristics

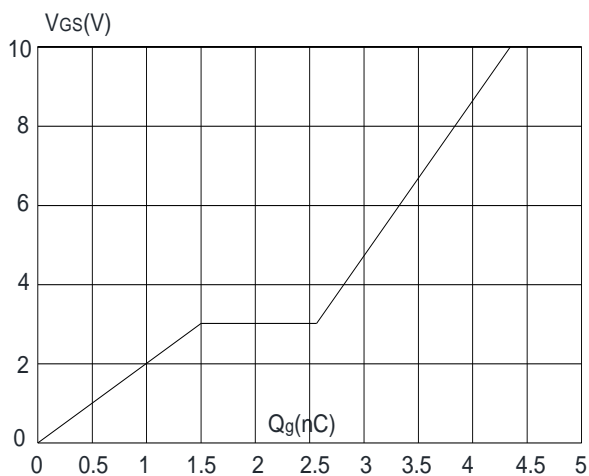
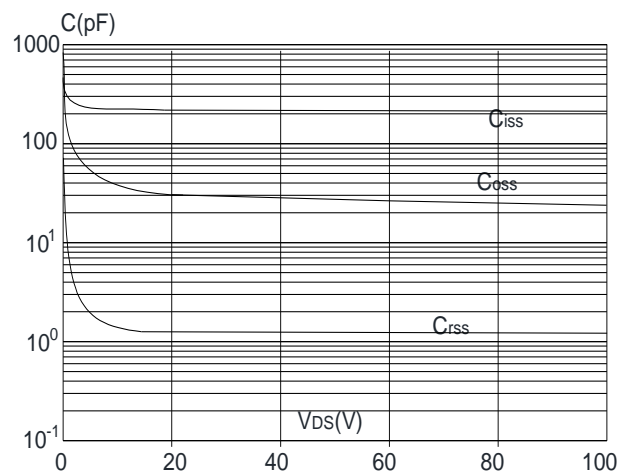

Figure 6: Capacitance Characteristics



TYPICAL PERFORMANCE CHARACTERISTICS (cont.)

Figure 7: Normalized Breakdown Voltage vs. Junction Temperature

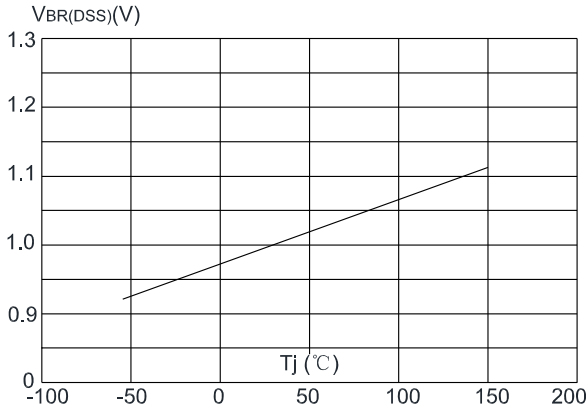

Figure 8: Normalized on Resistance vs. Junction Temperature

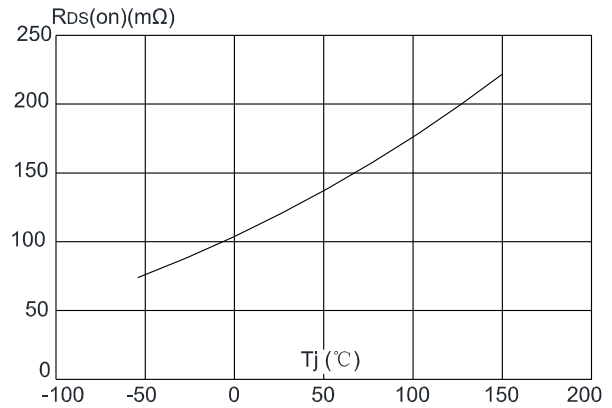

Figure 9: Maximum Safe Operating Area

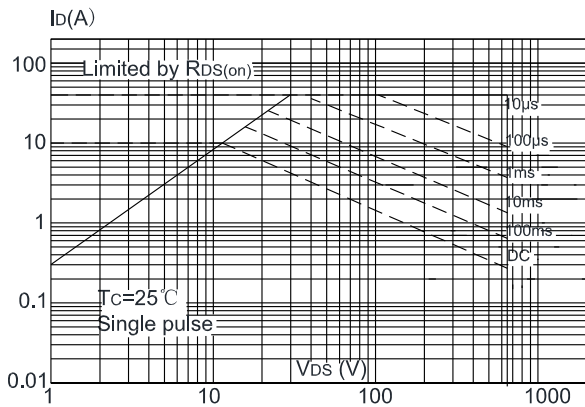

Figure 10: Maximum Continuous Drain Current vs. Case Temperature

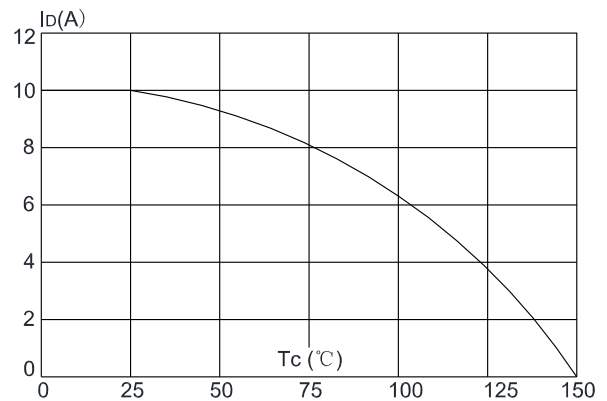
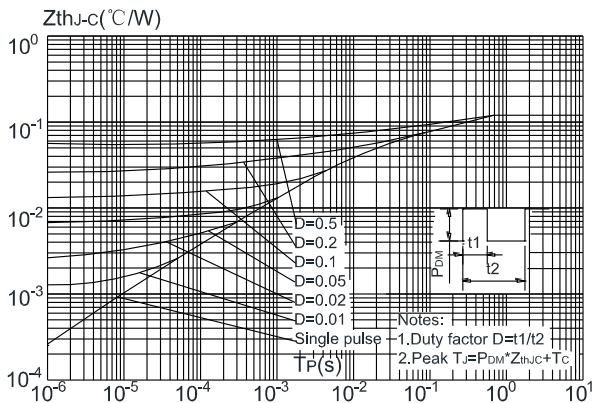
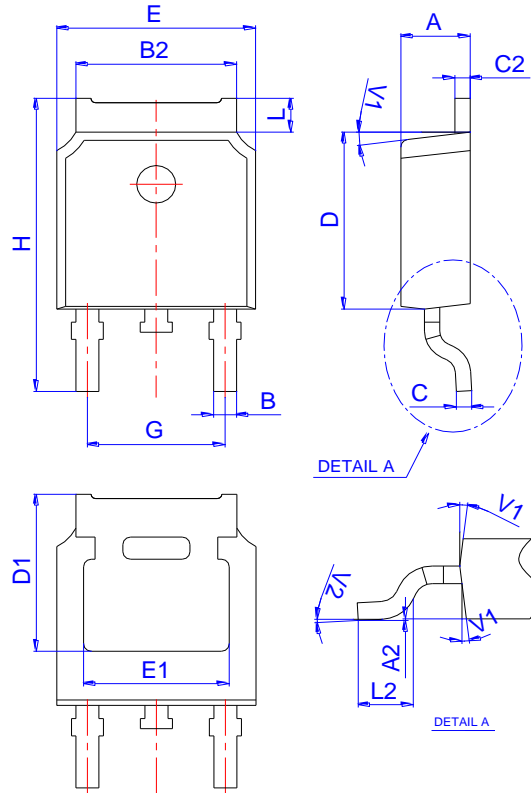

Figure.11: Maximum Effective Transient Thermal Impedance, Junction-to-Case



TO-252 PACKAGE OUTLINE DRAWING



Ref.	Dimensions					
	Millimeters			Inches		
	Min.	Typ.	Max.	Min.	Typ.	Max.
A	2.10		2.50	0.083		0.098
A2	0		0.10	0		0.004
B	0.66		0.86	0.026		0.034
B2	5.18		5.48	0.202		0.216
C	0.40		0.60	0.016		0.024
C2	0.44		0.58	0.017		0.023
D	5.90		6.30	0.232		0.248
D1	5.30REF			0.209REF		
E	6.40		6.80	0.252		0.268
E1	4.63			0.182		
G	4.47		4.67	0.176		0.184
H	9.50		10.70	0.374		0.421
L	1.09		1.21	0.043		0.048
L2	1.35		1.65	0.053		0.065
V1		7°			7°	
V2	0°		6°	0°		6°